

Commercial ATLAS 50CM SEMI RECESSED BASIN 2TH



Product Code	40009/1
Weight (Kg)	10
Material	Vitreous China
Tap holes	2
Fixings	Supplied with cutting template and fixing brackets

Key features:

- CE Compliant
- Clean-lined
- Internal overflow
- Fully glazed at rear
- Lifetime ceramic guarantee*

Description:

Matching current trends, these basins are clean-lined and feature no soapdish indents or raised ridges that could act as dirt or germ traps, making cleaning and maintaining hygiene even easier.

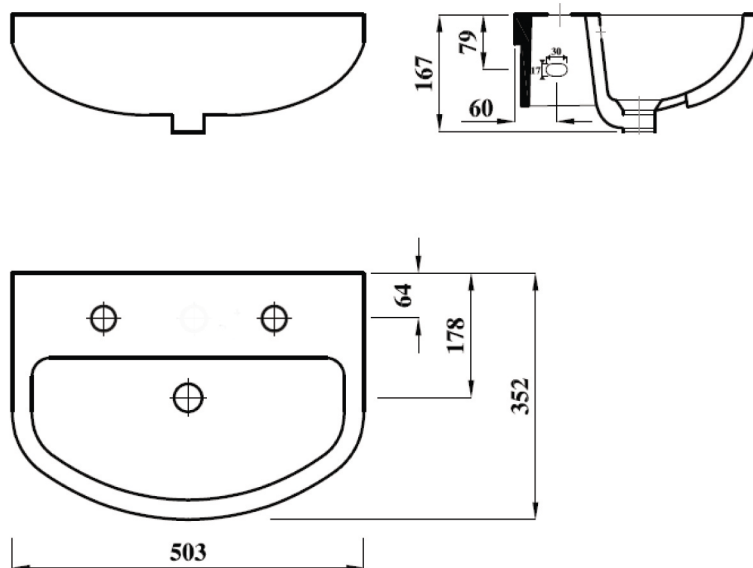

All dimensions are approximate and subject to normal ceramic variation. Although every effort is made not to change the above product specification, Washroom Warehouse reserves the right to do so without prior notification if necessary. *Against manufacturers defects. Full information on guarantees available upon request.