

Commercial Basin/Urinal Bowl Hanger Brackets



Product Code	40086
Weight (Kg)	0.1
Material	Steel

Key features:
•7UKCA Compliant

Description:
Brackets for Basin or Urinal Bowl

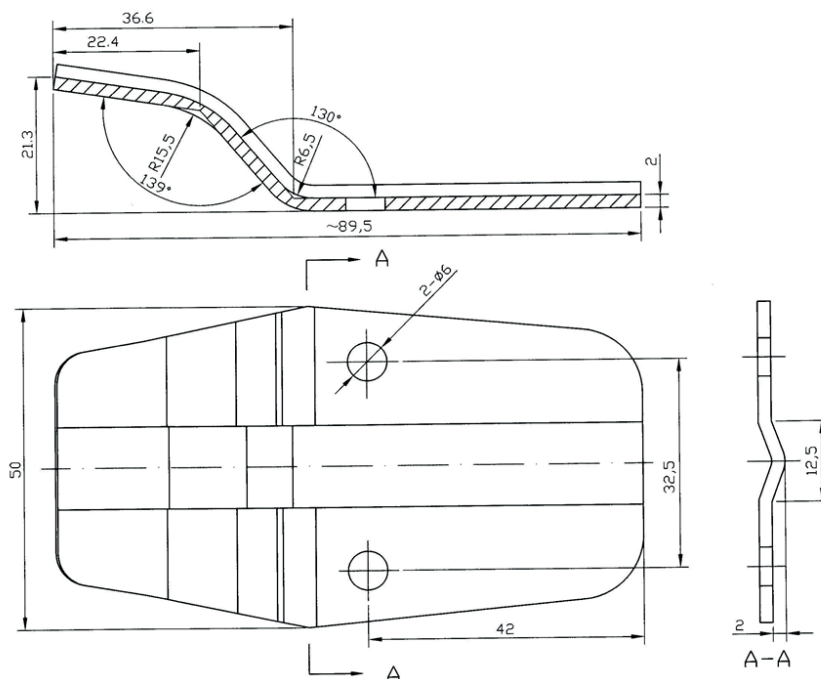

All dimensions are approximate and subject to normal ceramic variation. Although every effort is made to change the above product specification, Washroom Warehouse reserve the right to do so without prior notification if necessary. *Against manufacturers defects. Full information on guarantees available upon request.