

**WASHROOM**  
WAREHOUSE

# Wall-Hung Full Pedestal Basin 45cm with Essential Non- Concussive Tap (pair), Waste and Trap

Product Code: SABASWA4



Pack Contents:

40304 40021

40017 40018

40097

40114

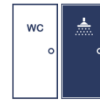

# Commercial Wall-Hung Basin 450x390mm - Two Tap Hole



<b>Product Code</b>	<b>40304</b>
<b>Weight (Kg)</b>	9
<b>Material</b>	Vitreous China
<b>Tap holes</b>	2

### Key features:

- UKCA Compliant
- C-shape Design
- Internal overflow
- Lifetime ceramic guarantee\*

### Description:

This basin features the latest smooth thin design with two tap holes. A modern revision of a classic basin. Can be paired with Semi Pedestal and Full Height Pedestal.

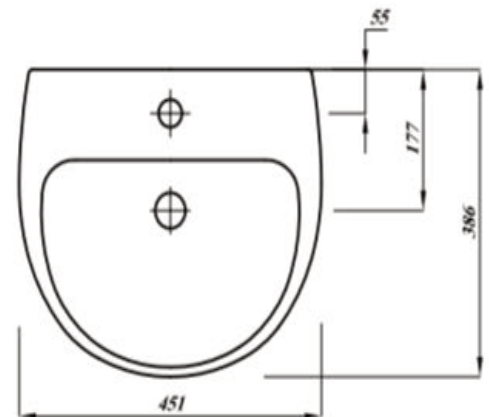
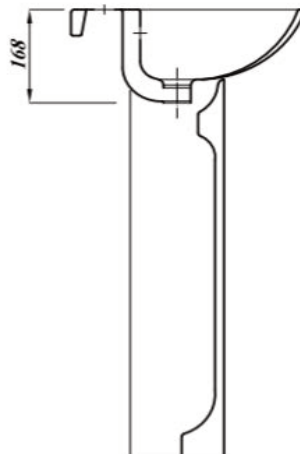
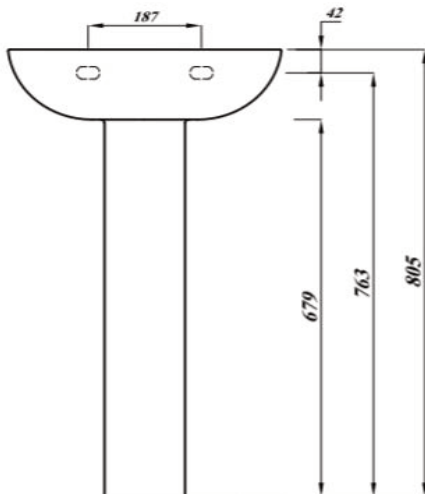

All dimensions are approximate and subject to normal ceramic variation. Although every effort is made not to change the above product specification, Washroom Warehouse reserve the right to do so without prior notification if necessary. \*Against manufacturers defects. Full information on guarantees available upon request.

## Non Concussive Basin Mounted Push Taps

inta taps used as water economy device operate for a period of time and then closes automatically



non concussive basin mounted tap (pairs)  
NC160CP

### Introduction

The Inta range of wall and basin mounted push taps is designed for use with our range of thermostatic mixing valves. With manual operation the tap functions for a period of time and then closes automatically. This operation makes the tap ideal for use in unsupervised areas such as sports changing rooms and washrooms. It is also perfect for use as a water economy device. The simple operation of the push tap enables users with limited mobility to use the facility.

Available in standard and contemporary styles the push tap is safe, reliable and reflects the quality of the intatec range of total washroom solutions.

- Simple operation
- Closes automatically
- Water economy
- Non concussive operation
- 2ltr, 4ltr and 5ltr flow regulator options available
- WEPLS accredited (NC160CP05)
- 3 second time flow version available (NC165CP)

### Product Range

Description	Code
Non Concussive Basin Mounted Taps (pairs)	NC160CP
Non Concussive Basin Mounted Taps (single)	NC160CP(S)
Non Concussive Basin Mounted Taps (pairs) WEPLS - 5ltr Per Minute	NC160CP5
Non Concussive Basin Mounted Taps (pairs) 3 Second Time Flow	NC165CP



**Water**

[www.europeanwaterlabel.eu](http://www.europeanwaterlabel.eu)



## Non Concussive Basin Mounted Push Taps

### Features

#### Technical Specification

Max Inlet Pressure	10 Bar
Min Inlet Pressure	0.1 Bar
Max Inlet Temperature	65°C
Timed flow (standard)	15 seconds at 1 bar

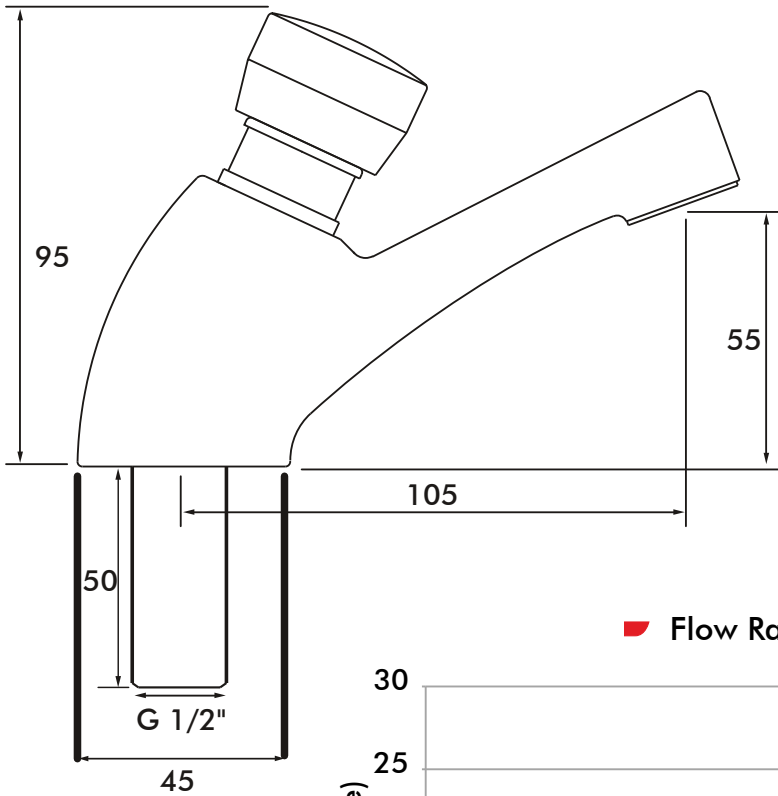

#### Flow Rates (Litres per minute)

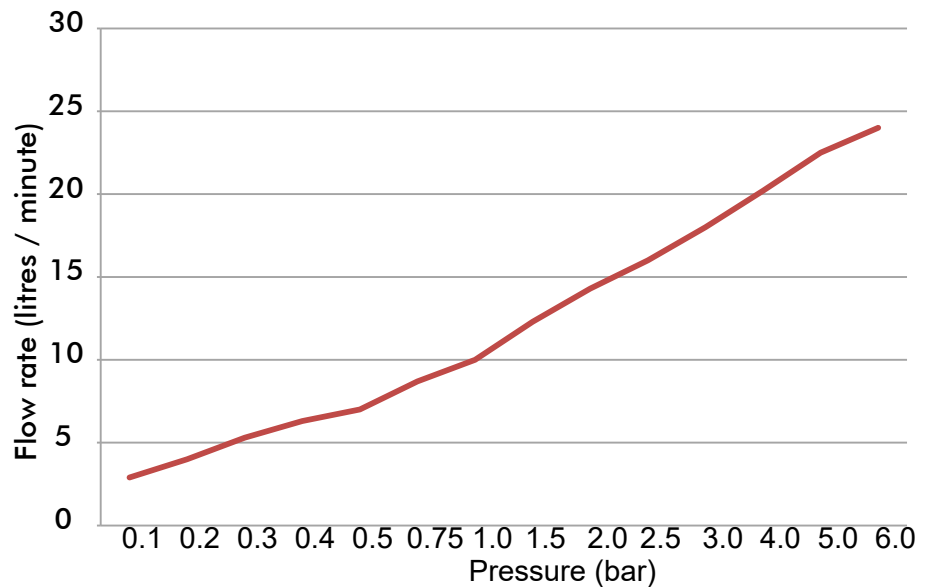

07/2018

AIRFIELD INDUSTRIAL ESTATE, HIXON, STAFFORD, ST18 0PF  
 T. 01889 272180 F. 01889 272181 E. SALES@INTATEC.CO.UK  
 WWW.INTATEC.CO.UK



**WASHROOM**  
 WAREHOUSE

Product Code: 40021

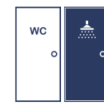

# Basin waste 32mm chrome / plastic plug

Product Code: 40017



# Trap 'P' 32mm AV

Product Code: 40018



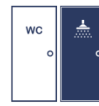

# Commercial ATLAS FULL PEDESTAL



<b>Product Code</b>	<b>40097</b>
<b>Weight (Kg)</b>	8.93kg
<b>Material</b>	Vitreous China

## Key features:

- Ideal for hiding pipework
- White finish
- Suitable for the wall hung basins
- Lifetime ceramic guarantee\*

## Description:

Atlas Pedestal White has been created for business professionals who demand value-for-money without quality compromise. This full height pedestal brings a modern look and feel to your bathroom while hiding the basin trap and pipes. This pedestal is for use with the 450mm 500mm and 550mm wall hung basins.

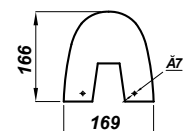
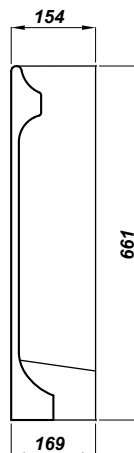
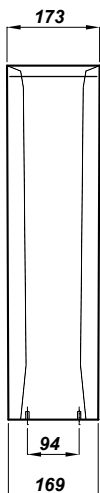

All dimensions are approximate and subject to normal ceramic variation. Although every effort is made not to change the above product specification, Washroom Warehouse reserve the right to do so without prior notification if necessary. \*Against manufacturers defects. Full information on guarantees available upon request.



# Commercial Wall Basin Fixing Kit



<b>Product Code</b>	<b>40114</b>
<b>Material</b>	Mixed
<b>Weight (Kg)</b>	1

**Key features:**

- Suitable for concrete, natural stone, solid brick or plasterboard and hollow blocks.
- Passivated finish

**Description:**

Fixing sets consisting of wall plugs, stud screws, nylon nuts or flanged bushes with hexagon nut:  
2 wall plugs - 14 x 75  
2 stud screws - M10 x 140 zinc-plated  
2 flanged nuts - BDH M10  
2 hexagon nuts - M10